

## A Study on Maximizing the Energy Density of a System by Choosing a Suitable Flywheel

Mohammad Dasseh, Samer Yahya\* and Jeffrey F Webb

Department of Mechanical, Materials and Manufacturing Engineering, The University of Nottingham Malaysia Campus, Jalan Brog, 43500 Semenyih, Selangor, Malaysia

### Abstract

Different types of flywheel energy storage systems have been studied in this work. A flywheel energy storage system can be thought of as a mechanical battery that stores energy kinetic energy. The objective is to maximize the energy density of the system. However, the parameters that we change to increase the energy stored in the system might cause the system to collapse if we exceed the maximum allowable stress (the yield strength of the flywheel's rotor material), hence, a stress analysis study for flywheel rotors is essential in order for us to find out if a rotor is capable of withstanding the given conditions in order to avoid failure. The challenge is to reduce the stress on the rotor in order for us to be able to have a greater angular speed. The results show that having a very large or very low number of spokes will cause failure to occur faster. A large number of spokes caused the failure to occur on the spokes, whereas a small number of spokes caused failure to occur on the rim of the rotor.

**Keywords:** Energy; Density; Parameters

### Introduction

Energy storage technology has been used for centuries in various applications. The need to store energy using a mechanical method has followed a distinctive pattern during the past few decades [1]. One such method of storage is flywheel technology. The main elements of a flywheel energy storage system are the rotor, magnetic bearings, motor/generator, and containment [2]. A flywheel energy storage system is unlike chemical or electrical storage systems as it stores energy in the form of a rotating mass (kinetic energy). The utilisation of a flywheel, an essential mechanical concept, has been refined using sophisticated modern technology to give the system very high efficiency for long periods of time. The rotor is hung inside a partial vacuum (reduced pressure) rigid containment, which prevents friction-losses from the air and protects the surroundings from any sudden failure [3]. In order to ensure that the rotor is running smoothly and the friction factor is minimised, the rotating mass is suspended by magnetic bearings. When the system is in the charging mode, the motor/generator works as a motor, the electrical energy that is supplied to the system is used to apply torque to the rotor, which rotates and stores the energy as kinetic energy. Conversely, the motor/generator works as a generator to transform the kinetic energy stored in the system into electrical energy when the system is in use [4].

One example of a flywheel energy storage system is the "Gyrobus", which was developed in 1953 with the intention of giving an alternative solution to the battery-electric buses for more efficient, quieter, and lower-frequency routes [5]. Today, flywheel energy storage systems have a wide range of applications. One example of a recent flywheel application is in power conditioning (to improve the machine when there is a mismatch between the device that requires input and the motor generated output which would cause instability [1]). Another beneficial application is using flywheel technology in hybrid vehicles, where kinetic energy is usually dissipated as heat energy via friction in the breaking plates when stopping the vehicle. However, in some hybrid vehicles, instead of wasting the kinetic energy as heat, it is taken from the gear to spin the rotor, hence preserving energy for vehicle acceleration which will require the engine to produce less energy. The engine therefore only needs to produce the power needed to overcome the steady-state loss and will not be required to provide full power

to move the vehicle, thereby causing the vehicle to use less fuel and accelerate more rapidly [6].

Flywheel energy storage systems (FESS) are mainly used for high power, low energy applications which need a large number of cycles and they are especially attractive for applications requiring repetitive cycling. Such mechanical batteries also have several advantages over chemical, biological, or electrical batteries. They have the ability to store more energy and their substantial durability allows them to be cycled repeatedly with no impact on the system's performance. Moreover, they have quick response and ramp rates, which allow them to go from complete discharge to full charge in very short time; they can also endure many partial and full charge-discharge cycles with little wear per cycle [7].

### Theoretical Background

#### Energy density

It is the aim of any flywheel designer to maximize the energy stored in the flywheel. Flywheel energy storage systems use kinetic energy stored in a rotating mass therefore eliminating any frictional losses. An electric energy motor rotates the mass via an integrated motor/generator device. The energy is supplied by converting the kinetic energy into electrical energy using the same motor/generator. The energy capacity of a flywheel is directly proportional to the rotor's moment of inertia multiplied by the square of its angular speed. To maximize the energy with respect to the mass, the flywheel is rotated at the maximum possible angular velocity [7].

\*Corresponding author: Samer Yahya, Department of Mechanical, Materials and Manufacturing Engineering, The University of Nottingham Malaysia Campus, Jalan Brog, 43500 Semenyih, Selangor, Malaysia, Tel: +60-3-8725-3557; E-mail: [Samer.Yahya@nottingham.edu.my](mailto:Samer.Yahya@nottingham.edu.my)

Received January 06, 2015; Accepted January 06, 2015; Published January 16, 2015

Citation: Dasseh M, Yahya S, Webb JF (2015) A Study on Maximizing the Energy Density of a System by Choosing a Suitable Flywheel. Global J Technol Optim 6: 171. doi:10.4172/2229-8711.1000171

Copyright: © 2015 Dasseh M, et al. This is an open-access article distributed under the terms of the Creative Commons Attribution License, which permits unrestricted use, distribution, and reproduction in any medium, provided the original author and source are credited.

$$E_k = \frac{1}{2} I \omega^2$$

We can say that a flywheel's energy density is defined as the amount of energy that can be stored in its rotor per unit mass or volume. This can also be related to the enthalpy per unit volume [8].

### Moment of inertia

Flywheel energy storage systems store energy in the form of kinetic energy as a rotating mass in the rotor. The amount of energy that a rotor carries changes according to the moment of inertia, and with the square of the angular speed of the rotating mass. The moment of inertia is defined to be the integral of the square of a certain distance from the axis of rotation to the differential mass. Generally we can say that the capacity of flywheel storage can be determined by the polar moment of inertia and the maximum safe angular velocity that the rotor can withstand. The cyclic torque variation, the allowable speed variation, and the maximum energy necessary are the main components in determining the required inertia; however, the safe running speed varies according to the material properties and the geometry of the rotor [7].

For a rotor the dominant shape is a solid cylinder:  $I = \frac{1}{2} m r^2$

$$m = \frac{1}{2} r^4 \rho a \pi$$

But as the shape that we are dealing with is a hollow cylindrical flywheel consists of steel rim attached to a shaft with a web we find:

$$I = \frac{m(r_o^2 + r_i^2)}{4} = \frac{\pi a \rho (r_o^4 + r_i^4)}{4}$$

### Spinning speed

Rapidly rotating rotors encounter significant centrifugal forces. Whilst a dense material allows for a large energy density capacity, it actually poses a higher risk of failure due to a higher centrifugal force, when running at lower rotational speeds in comparison to low-density materials. Thus, tensile strength is more important than the density of the material [9]. Flywheels with relatively low spinning speed are designed from steel and revolve with an angular velocity up to 10,000 rpm. However, advanced energy density flywheel energy storage systems, which accommodate rotational speeds of up to 100,000 rpm, are achievable if designed under the following constraints:

1. Using fiberglass resins or polymer materials with a high specific strength for the rotor.
2. Spinning the rotor in a vacuum in order to minimize the aerodynamic drag.
3. Spinning the rotor at high frequency.
4. Using magnetic bearing technology to provide high angular speed.

The maximum allowable rotational speed for a flywheel rotor varies according to the ability of the material of the rotor to withstand the force that is applied to it (tensile strength). The main force we are to consider is the centrifugal forces. Hence, energy density (energy per unit volume) and specific energy (energy per unit mass) are shown

accordingly in the following equations:  $E_v = K \sigma_{\theta,u}$ ;  $E_m = K \frac{\sigma_{\theta,u}}{\rho}$

For instance the following Table 1 shows a comparison between characteristics of flywheels composed of different materials.

Material name	Density (kg/m <sup>3</sup> )	Max. stress (MPa)	Energy density (MJ/m <sup>3</sup> )	Specific energy (kJ/kg)
Aluminium	2700	500	251	93
Steel	7800	800	399	51
Glass (E/Epoxy)	2000	1000	500	250
Graphite (HM/epoxy)	1580	750	374	237
Graphite (HS/Epoxy)	1600	1500	752	470

**Table 1:** Materials with their corresponding density and maximum stress, to compare between their energy density and specific energy.

A flywheel having low density and high tensile strength materials will allow us to obtain a high specific-energy rotor, which will allow a higher rotational speed (an example of that is modern composite materials). On the other hand, metals generally have a large density which allow a relatively high energy density to be obtained, but does not allow high rotational speeds, which also gives them a lower price than composite materials.

### Rotor's size and shape

The shape factor is a dimensionless factor which depends mainly on the geometrical shape of the design, other factors that also have impact on the shape factor are the physical properties (isotropy, material, lamination, etc.), and the stress distribution. The shape factor is also known as the linear scaling factor between the stored energy density by a rotor and its specific strength.

When we have a limited stress case the shape factor is a measure of the shape efficiency of the rotor. The maximum value is 1 for the ideal isotropic rotor with the Stodola shape (a nano-scale rotor supported on a cantilevered multi-wall carbon nanotube shaft). The Stodola rotor has a constant stress profile and infinite radius. The range for a practical isotropic rotor is between 0.3 for a thick isotropic rim with a vanishingly small centre bore and 0.8 [9]. See Table 2 for some examples.

### Stress analysis

For flywheels with a simple rim, the maximum energy density varies according to the tensile strength of the material as:  $E_{v,max} = \frac{1}{2} \sigma_{max}$ ;  $E_{m,max} = \frac{1}{2} \frac{\sigma_{max}}{\rho}$

The maximum specific energy can be calculated from the following equation:

Hence, we can achieve maximum energy storage capacity by choosing low density, high tensile strength materials. Energy density and specific density are important factors, where the respective level of importance is determined by the application. For instance, mass energy density is a major factor in transportation applications [7,10].

Three-dimensional interactions of stresses are to be taken in consideration for such a study. These interactions will limit the allowed angular velocity of the rotor, and hence limit the maximum allowable energy density [11]. For such a design, the axial stress has an insignificant effect on the rotor, so we are left to study the radial stress and the hoop stress ( $\sigma_r, \sigma_\theta$  respectively).

For a hollow circular cylinder rotor design:

- The radial stress can be determined by the following equation:

$$\sigma_r = \frac{3+v}{8} \times \rho \omega^2 \times \left( r_o^2 + r_i^2 - \frac{r_o^2 r_i^2}{r^2} - r^2 \right)$$







Geometry shape	Sectional view	Shape Factor
Disc		1.00
Modified constant stress disc		0.93
Conical disc		0.81
Flat unpierced disc		0.61
Thin firm		0.50
Shaped bar		0.50
Rim with web		0.40
Single bar		0.33
Flat pierced bar		0.31

Table 2: Shape factor K, for various geometry shapes and their corresponding values) [10].

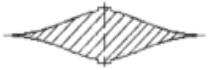
- The hoop stress can be determined by the following equation:

$$\sigma_{\theta} = \frac{3+\nu}{8} \times \rho \omega^2 \times \left( r_o^2 + r_i^2 + \frac{r_o^2 r_i^2}{r^2} - r^2 \times \frac{1+3\nu}{3+\nu} \right)$$

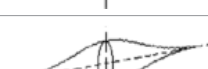
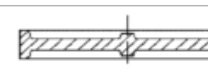
In considering the effects of the spokes for a rotor with bending, we will first assume that all of the spokes have a constant cross-sectional area using Castigliano's theorem [12]. The tensile stress in a thin rotor (including bending), can be calculated using the following method:

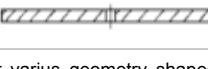
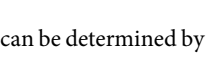
First, calculate the intermediate values:  $f_1 = \frac{1}{2 \sin^2 \alpha} \times \left( \frac{\sin 2\alpha}{4} + \frac{\alpha}{2} \right)$

$$f_2 = f_1 - \frac{1}{2\alpha}, f_3 = \frac{Ar_a^2 f_2}{I} + f_1 + \frac{A}{A_s}, f_4 = \frac{\cos \beta}{f_3 \sin \alpha};$$

- The values  $f_1 f_2 f_3 f_4$  are then substituted into the beam equation:

$$\sigma = \frac{r_a^2 \rho \omega^2}{g} \times \left[ 1 - \frac{f_4}{3} + \frac{Ar_a}{3Z_r} \times \left( f_4 - \frac{1}{f_3 \alpha} \right) \right]$$

Note: when calculating the beam equation, the sign of the section modulus  $Z_r$  is substituted as a positive value for the external face of the rim, and as a negative value for the inner face.

- In addition, we can calculate the stress in the spokes separately by using the following equation:

$$\sigma_2 = \frac{\rho r_a^2 \omega^2}{6g} \times \left( 3 + \frac{4A}{f_3 A_s} - \frac{3r^2}{r_a^2} \right)$$

Note: Bending stresses in the spokes will occur, as the energy is exchanged with the flywheel [13]. We can calculate the resultant torque

by using the following methods:

- Calculating the maximum torque of the rotating shaft.

- The minimum braking time.

When the flywheel works as a pulley, we can calculate the torque by determining the force difference exerted on the rope between the power and slack sides.

- For a thin rim, the hub will experience the maximum bending stress on the spokes (we assume that the spokes do not erode more than the 25%) [4].

- The bending stress on the hub can be calculated from equation:

$$\sigma_2 = \frac{T(r_a - r_h)}{Z_s N_s r_a}$$

## Results and Discussion

### Theoretical calculation

The flywheel studied in this set of experiments was made of cast iron (density of  $0.283 \text{ lb/in}^3$ ) with a rectangular rim with thickness of  $5 \text{ inch}$  and width of  $11 \text{ inch}$ , it had an average radius of  $48 \text{ inch}$ . The hub of the rotor had a radius of  $5.2 \text{ inch}$ . The design had 8 spokes, each of them had an area of  $11 \text{ inch}^2$ . This rotor is to spin at a maximum speed of  $400 \text{ rpm}$  which produces a maximum possible torque of  $4000 \text{ lb.ft}$  (with the assumption that the maximum stress occurs at the inner surface of the rotor's rim) [12].

- First we calculate the following parameters

$$A = (5) \times (11) = 55 \text{ inch}^2$$

$$\omega = \frac{2\pi(400)}{60} = 41.9 \text{ rad/sec}, I = 11 \times \frac{(5)^3}{12} = 114.6 \text{ inch}^4,$$

$$Z_r = 11 \times \frac{(5)^2}{6} = 45.8 \text{ inch}^3, \alpha = 22.5 \text{ degrees}(\pi/8); \beta = \pi/8$$

$$Z_s = \pi \times (2.65)(5.29) / 32 = 7.28 \text{ inch}^3$$

- Next the intermediate values

$$f_1 = \frac{1}{2 \sin^2 \left( \frac{\pi}{8} \right)} \times \left( \frac{\sin 2 \left( \frac{\pi}{8} \right)}{4} + \frac{\left( \frac{\pi}{8} \right)}{2} \right) = 1.274$$

$$f_2 = 1.274 - \frac{1}{2 \left( \frac{\pi}{8} \right)} = 7.6 \times 10^{-4}$$

$$f_3 = \frac{(55)(48)^2 (7.6 \times 10^{-4})}{(114.6)} + (1.274) + \frac{(55)}{(11)} = 7.11$$

$$f_4 = \frac{\cos \left( \frac{\pi}{8} \right)}{(7.11) \sin \left( \frac{\pi}{8} \right)} = 0.34$$

- To calculate the stresses, the values are substituted into the beam theory equation as follows:

$$\sigma = \frac{(48)^2(0.283)(41.9)^2}{(32.2 \times 12)} \times \left[ 1 - \frac{(0.34)}{3} + \frac{(55)(48)}{3 \times (-45.8)} \times \left( (0.34) - \frac{1}{(7.11)\left(\frac{\pi}{8}\right)} \right) \right] = 3666 \text{ psi}$$

The maximum stress applied on a spoke can then be found from:

$$\sigma_1 = \frac{(0.283)(48)^2(41.9)^2}{6(32.2 \times 12)} \times \left( 3 + \frac{4(55)}{(7.11)(11)} - \frac{3(5.2)^2}{(48)^2} \right) = 2850 \text{ psi}$$

Note: the prototype designed was mainly based on this example, hence, in order to ensure that the modelled study is accurate; the maximum stress applied on the spoke should match the theoretical value obtained from the previous equation.

The bending stress in the spokes can be obtained from:

$$\sigma_2 = \frac{(4000)(48 - 5.2)}{(7.28)(8)(48)} = 61 \text{ psi}$$

The total stress applied on the spoke is the sum of  $\sigma_1$  and  $\sigma_2 = 2910 \text{ psi}$

### Study results

**Triangle shape:** From Table 3 we can see that the 8 -spoke rotor, with maximum stress at 41.9 rad/s is 2973.4 psi, which is very close to the theoretical value (2880.0 psi) (Figure 1). The emerging trend from these results, which is highlighted in Figure 2, shows that when we have very large or small number of spokes the stress is generally higher,

No. of spokes	Stress on the rim at 41.9 rad/s (psi)	Max. stress at 41.9 rad/s (psi)	Max. angular speed (rad/s)
10	4270.9	5694.4	112.4
8	1705.9	2973.4	97.6
6	2598.4	4164.2	130.9
4	2897.5	4810.2	115.3
2	3429.5	4839.1	123.1

Table 3: Results obtained from Solid works for the triangle shape.

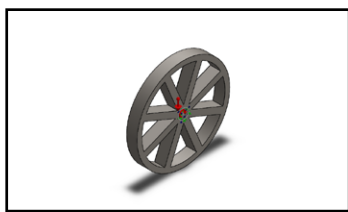

Figure 1: The general shape of the triangle design.

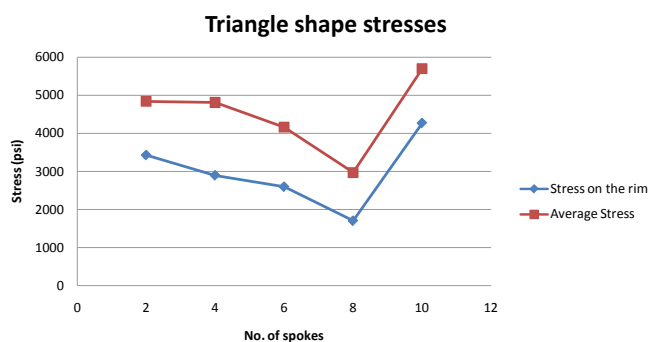

Figure 2: Stress versus No. of Spokes, for the triangle shape.

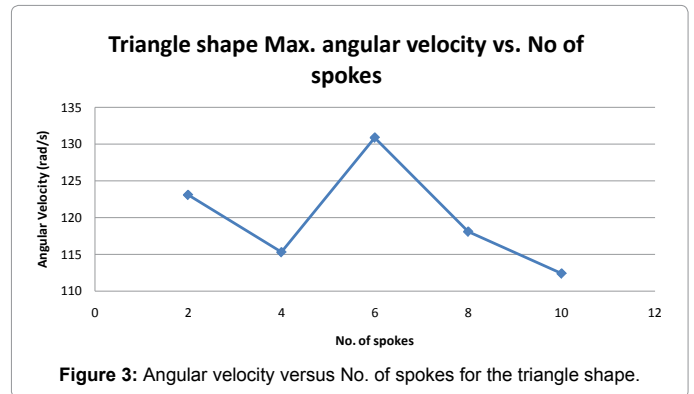

Figure 3: Angular velocity versus No. of spokes for the triangle shape.

No. of spokes	Stress on the rim at 41.9 rad/s (psi)	Max. stress at 41.9 rad/s (psi)	Max. angular speed (rad/s)
10	2393.6	4103.0	133.4
8	1083.6	2829.5	160.8
6	1111.6	2667.1	165.6
4	1331.1	2281.3	177.8
2	1993.1	3985.6	134.4

Table 4: Results obtained from Solid works for the circular shape.

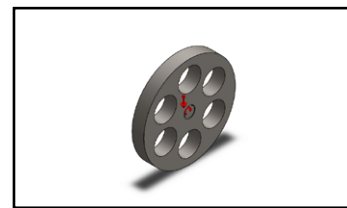

Figure 4: The general shape of the circular design.

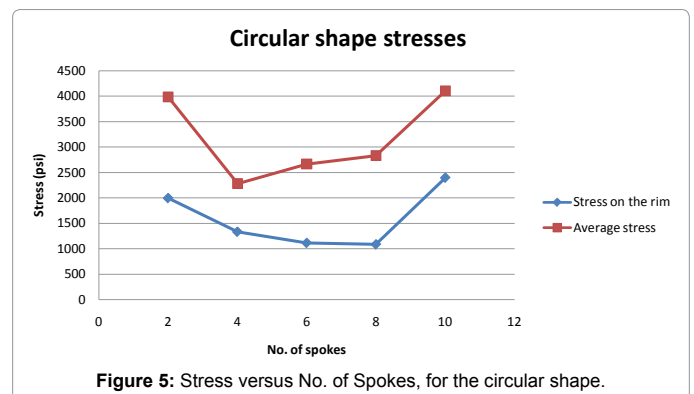

Figure 5: Stress versus No. of Spokes, for the circular shape.

whereas for an intermediate number of spokes the stress is generally lower. Figure 3 shows the angular velocity for the different spoke numbers in this particular design. For 6 spokes the angular velocity is highest, and then decreases until 10 spokes are reached. However we would expect that 4 spokes would have a higher angular velocity than is actually shown in Figure 3. This could be because the deformed shape of the 4-spoke rotor tends to be more square-like, which would impede the angular velocity to a greater extent than for example the 2-spoke rotor.

**Circular shape:** From Table 4 the same trend was observed with the circular shape (Figure 4), as backed up by Figure 5. In addition to

this there was generally a lower overall stress on the rim compared to the triangular shape. This lower stress allows for a higher maximum angular speed, shown in Figure 6, which increases the energy density of the system. The lower maximum stress could be due to the stress being more evenly distributed on the rotor further from the center, which would thus lead to a higher maximum angular velocity.

**Shape 1:** From Table 5 it is shown again that with shape 1 (Figure 7), stress is generally less when we have 8 or 6 spokes in the rotor, thus a higher maximum allowable angular speed is available. On the other

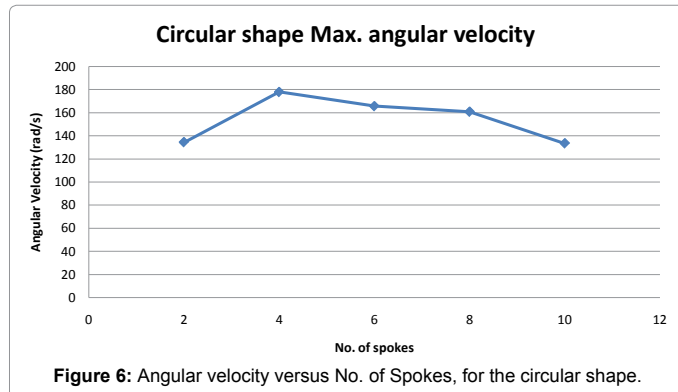

No. of spokes	Stress on the rim at 41.9 rad/s (psi)	Max. stress at 41.9 rad/s (psi)	Max. angular speed (rad/s)
10	1841.2	2454.7	171.5
8	1319.1	2637.4	164.8
6	1383.7	2075.3	186.3
4	2159.0	3088.3	153.4
2	2367.9	4733.8	122.3

**Table 5:** Results obtained from Solid works for shape 1.

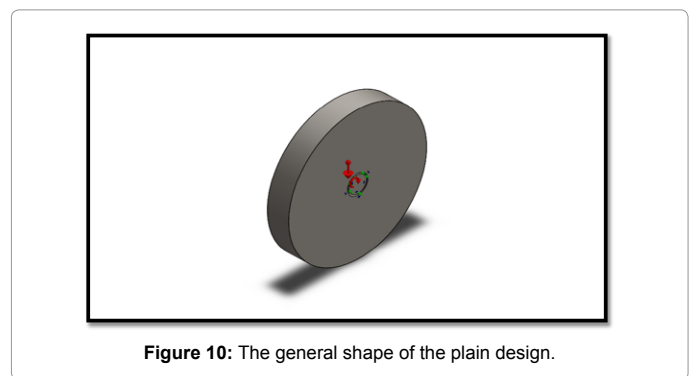
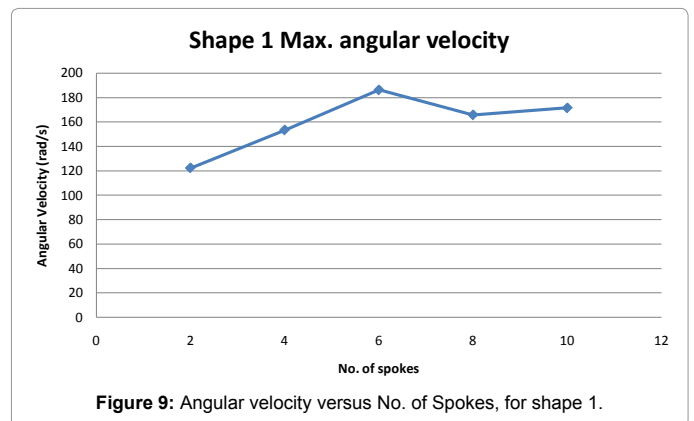
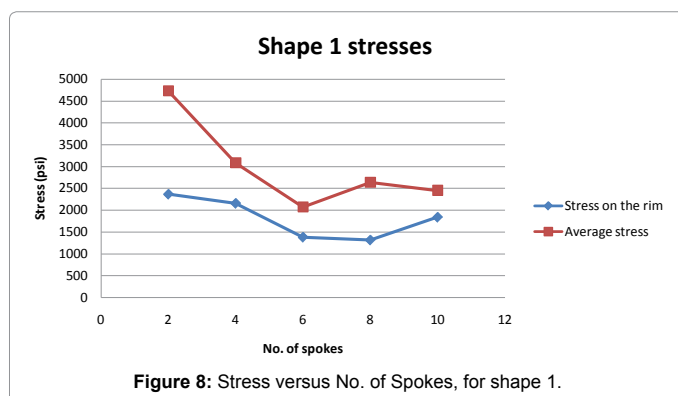
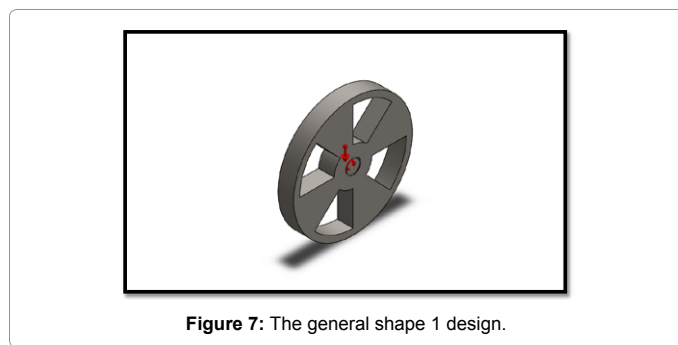

No. of spokes	Stress on the rim at 41.9 rad/s (psi)	Max. stress at 41.9 rad/s (psi)	Max. angular speed (rad/s)
0	390.8	1171.3	253.8

**Table 6:** Results obtained from Solid works for the plain shape.

hand, with 2 and 4 spokes the stress is higher and its angular speed is lowest. But it is also interesting to note that for the 10 spoke variation the stress is also relatively low, with a high angular speed, as shown in Figures 8 and 9. It could be that this particular shape has a different threshold and can withstand a higher number of spokes before the stress exceeds the yield strength. This may be due to the geometry of the shape or the distance of the hole from the centre of the rotor. However to explore this possibility further studies would have to be undertaken.

**Plain shape:** In a separate study the plain design in Figure 10 was considered, which has a smaller diameter to maintain the same mass of the original rotor (Table 6). The design followed the same materials, fixture, connectors, and load details as the previous study; the only difference was the outer diameter of the rim which was reduced to 1.8 inch.

The rotor is connected through the hollow core of the hub in the center to the drive shaft. Although the plain design is capable of achieving very high angular speed an optimal design (as seen previously) for the hub can help reduce the stress distribution in the rotor and eventually increase stored energy in addition to dissipating the heat from the rotor by increasing the surface area of the design.

However, it should be taken in consideration that a very large or very small number of spokes might disturb the stress distribution. A large number of spokes will limit the thickness of the spokes to fit all the holes on the design. This will then cause failure to occur on the spokes. A small number of spokes will cause failure to occur on the rim of the

rotor as the rim must become thinner with thicker spokes to maintain the same mass for all designs [13].

## Conclusion

The results of this study showed that when having 2- or 10-spoke flywheels, failure occurred faster for the triangular and circular shapes. This leads to a reduction in the maximum allowable angular velocity before the rotor material reaches the maximum yield strength; therefore less energy was stored in the system. Shape 1 however showed high stress with 2 spokes, but at 10 spokes the stress was still relatively low, which suggests that the stress threshold may be higher for this shape. Generally a large number of spokes caused the failure to occur on the spokes as the thickness of the spokes reduces; on the other hand a small number of spokes caused failure on the rim of the rotor as the thickness of the rim reduced in order to maintain the same mass.

## References

1. Beatty SM, Brett J, Fausz JL (2004) A Review of Technology Developments in Flywheel Attitude Control and Energy Transmission Systems. Proceedings of the IEEE Aerospace Conference, Boston, Massachusetts 4: 2784-2800.
2. Tang J, Zhang Y, Fang J (2007) Superconducting Levitation Styles for Superconducting Energy Storage Flywheel, 2007 Int. Conf. Mechatronics Autom, 2889-2893.
3. Horner RE, Systems IE, Road CH, Wirral S (1996) The Key Factors in the design and construction of advanced Flywheel Energy Storage Systems and their application to improve telecommunication power back-up, Proceedings of the IEEE Intelec'96 - International Telecommunications Energy Conference, Big Sky, Montana, 668-675.
4. Bolund B, Bernhoff H, Leijon M (2007) Flywheel energy and power storage systems, *Renew. Sustain. Energy Rev* 11: 235-258.
5. Buchroithner A, Andrašec I, Bader M (2012) Optimal system design and ideal application of flywheel energy storage systems for vehicles, Proceedings of the IEEE International Energy Conference and Exhibition, Florence, Italy, 991-996.
6. Arborio N, Riva N, Suraci E, Velardocchia M (2000) Vehicle Dynamics and Stability Analysis with Matlab and Adams Car, In: *Titolo volume non avvalorato*, 15th ADAMS European Users Conference, Rome, Italy, 15-17.
7. Farahani KM (2012) Modeling and Analysis of a Flywheel Energy Storage System for Voltage Regulation, Master's Thesis, Ryerson University, Toronto, Thesis and dissertations. Paper 1288.
8. Coombs T, Campbell AM, Storey R, Weller R (1999) Superconducting magnetic bearings for energy storage flywheels. *IEEE Trans, Applied Supercond* 9: 968-971.
9. Acebal R (1996) Effect of shape factor, operating stresses, and electrical conductors on the energy density of rotating machines. *IEEE Trans Magn* 32: 421-425.
10. Pilat AK (2011) Introduction to COMSOL based Modeling of Levitated Flywheel Rotor, Proceedings of the Comsol Conference, Stuttgart.
11. Tang J, Zhang Y (2012) High-Speed Carbon Fiber Rotor for Superconducting Attitude Control and Energy Storage Flywheel, 2012 Third Int. Conf. Digit. Manuf. Autom., pp. 477-481.
12. Beer FP, Johnson ER, DeWolf DT, Mazurek DF (2012) *Mechanics of Materials*, 6ed, McGraw-Hill, New York, 2012.
13. Caprio V, Lelos J, Herbst D, Upshaw J (2005) Advanced Induction Motor Endring Design Features for High Speed Applications, *IEEE Int. Conf. Electr. Mach. Drives*, pp. 993-998.

Citation: Dasseh M, Yahya S, Webb JF (2015) A Study on Maximizing the Energy Density of a System by Choosing a Suitable Flywheel. Global J Technol Optim 6: 171. doi:10.4172/2229-8711.1000171

### Submit your next manuscript and get advantages of OMICS Group submissions

#### Unique features:

- User friendly/feasible website-translation of your paper to 50 world's leading languages
- Audio Version of published paper
- Digital articles to share and explore

#### Special features:

- 400 Open Access Journals
- 30,000 editorial team
- 21 days rapid review process
- Quality and quick editorial, review and publication processing
- Indexing at PubMed (partial), Scopus, EBSCO, Index Copernicus and Google Scholar etc
- Sharing Option: Social Networking Enabled
- Authors, Reviewers and Editors rewarded with online Scientific Credits
- Better discount for your subsequent articles

Submit your manuscript at: <http://www.editorialmanager.com/biochem>