

Power Analysis for a Limited Bus Grid System with Distribution Generators

Nader Barsoum*, Christopher Asok, David Kwong and Clifford Thien Kit

Department of Electrical and Electronic Engineering, University Malaysia Sabah, Malaysia

Abstract

It has been recognized recently that when injecting renewable energy source power to a load buses which connected to some distributed feeders in a power grid system, a stability problem occurs particularly when having high fault duties that exceeding the circuit breaker ratings at some substations. In this paper an analysis of power flow, short circuit, stability and protection are given in detail to an example of limited 7-bus power grid system. Comparison are illustrated between power grid with and without distributed generators regarding bus voltages, fault currents, critical power angles, selected current transformers and over current relay settings in each bus. It discusses the selection of optimum slack bus in Gauss Seidel method, and shows that the system with distributed generators is more stable although the fault currents are higher than the system without distributed generators.

Keywords: Power grid; Bus voltages; Fault currents; Critical angle; Critical clearing time; Over current relay setting

Introduction

Recently, it is noticed that stability problem in power generation and relay setting problem occur due to high fault in distribution feeders which may probably cause by the injecting distribution generators in the load buses. Consumers like to use renewable energy sources installed in their home, factories, hospitals or moles and get a license to connect them to the power grid. The connection is found to be at distribution feeders which connected to the substation buses. This causes sometimes high fault duty and instability in the grid as well as exceeding the values of relay rate in some substations.

Normally the power system stability is analyzed in terms of bus voltages at steady-state and during fault and determined by critical clearing angle [1]. The phenomenon of bus voltage collapse due to a dynamic load in the power network is analyzed by simple power system model [2]. This voltage instability can also be analyzed by transferring the system model into a singular perturbation theory and solved by numerical investigation [3]. This voltage dropping at transient during fault leads to system disruption, which may be due to the maximum load power transfer from generation stations to load buses. Contingency analysis was presented in [4] and shows the post-contingency load flow and modified load flows in time domain. The contingency analysis and post-contingency analysis were used for long-term voltage stability; the credible contingencies are outages of transmission and generation facilities; in which a system must be able to withstand any single transmission or generation outage.

In this paper stability analysis is given for a simple limited 7-bus grid when a symmetrical 3-phase fault occurs at each bus. Comparisons between network with and without distribution generators are illustrated. This investigates the stability problem and avoided by calculating the critical angle and the corresponding critical clearing time to set up the over current relay at each bus.

The analysis started by load flow [5] using Gauss-Seidel method to calculate the optimum bus voltages by selecting suitable slack bus in the system. This is followed by calculating the fault current and the corresponding bus voltages at transient [6] considering the bus impedance matrix which is the inverse of the bus admittance matrix. Stability analysis is represented by calculating the critical angle in each

bus based on the reactance values of the diagonal in the bus impedance matrix and the pre-fault bus voltages from load flow results with the transient voltages during fault from the short circuit results [7]. This is followed by the calculation of the critical clearing time assuming a constant moment of inertia in all turbine-generator system. This time is used for setting the relay and circuit breaker at each bus [8].

Power Grid Model

An example is taken for this analysis represented by a simple power network [8]. It consists of 7 buses; the first 2 are considered fuel power stations referred to generating bus which generates 22 kV each. The next 3 buses are transmission busses include 5 transformers and 4 transmission lines (3 medium with 275 kV and one short with 132 kV). The last 2 are the distribution buses, one for heavy industrial area and one for residential area. Bus 6 step down from 33 kV to 11 kV in 3 distributed feeders and then to 400 V to the shop moles. Bus 7 is connected to 20 distributed feeders with 6.6 kV each then step down to 400 V to about 85 houses or flat units or shops in each feeder. These 2 bus loads are combined in one total load in each bus as shown in Figure 1. The consumers in these 2 areas are considering installing a renewable energy sources in each feeder, represented by distributed generators connected to the bus 6 and 7 giving the total power generation as shown in Figure 2. In order to investigate the process of calculation of power and line flow, the powers of the distributed generators (DG) are considered to be less than the power of loads in bus 6 and 7.

The per unit values of power, admittance and impedance of all components in the grid can be calculated from its concept. These values are given in the network of Figure 3. Admittance and impedance

*Corresponding author: Nader Barsoum, Department of Electrical and Electronic Engineering, University Malaysia Sabah, Malaysia, Tel: 6088320000; E-mail: nader@ums.edu.my

Received June 28, 2017; Accepted September 01, 2017; Published September 04, 2017

Citation: Barsoum N, Asok C, Kwong D, Kit CT (2017) Power Analysis for a Limited Bus Grid System with Distribution Generators. Global J Technol Optim 8: 216. doi: 10.4172/2229-8711.1000216

Copyright: © 2017 Barsoum N, et al. This is an open-access article distributed under the terms of the Creative Commons Attribution License, which permits unrestricted use, distribution, and reproduction in any medium, provided the original author and source are credited.

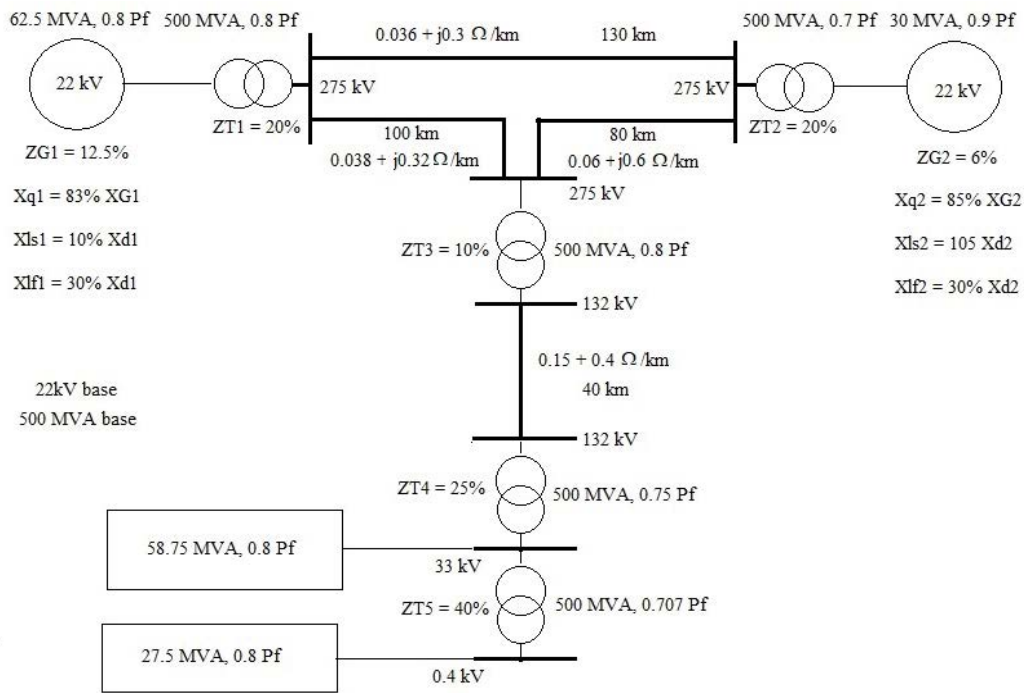

Figure 1: 7-bus Power Grid System without distributed generators.

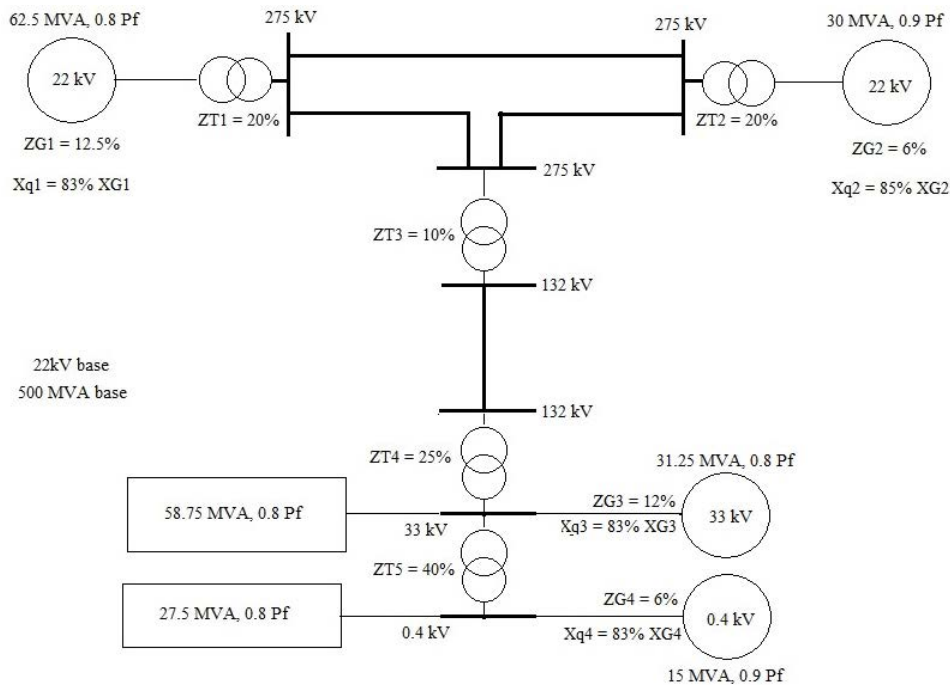

Figure 2: 7-bus Power Grid System with distributed generators.

matrices can be easily obtained, as in (1), (2), (3), (4).

Bus admittance matrix without distributed generator (1)

Bus impedance matrix without distributed generator (2)

Bus admittance matrix with distributed generator (3)

Bus impedance matrix with distributed generator (4)

The only different in admittance matrix between (1) and (3) is found

in the last 2 columns and rows, which are related to the distribution busses. While the inverse of admittance matrix shows quite different in impedance matrix between (2) and (4). Gauss-Seidel method is applied to this power network in both cases, with and without distributed generators. A numerical solution for the per unit bus voltages at steady-state is performed using MATLAB program for this system. The solution of voltage values in each bus is repeated 7 times for a selected slack bus with 1 per unit voltage. Table 1 shows the bus voltage values when selecting each bus as slack.

It can be seen from Table 1 that the realistic values of voltages at load buses 6 and 7 are smaller than the values of generating bus 1 and 2. Slack bus 5, 6 and 7 satisfy this property. However, the optimum values of bus voltages are the values that are very close to 1 per unit to have minimum line losses. Hence bus 5 is the suitable bus to be

selected as slack. Similar result is obtained for grid with distributed generators connected to bus 6 and 7. Figure 4 shows the comparison of the magnitude of bus voltages when bus 5 is slack.

This result is considered a novel investigation to select the optimum slack bus, unlike the analysis given in the literatures which are usually selecting bus 1 as slack.

The number of iterations to reach the accuracy of Gauss method is given in Figure 5. It can be seen from Figures 4 and 5 that the values are almost the same in bus 1 to bus 4, but are different in bus 6 and 7 since they are the distribution buses.

The analysis is processed to evaluate the bus current and the generator voltages $E = \text{bus voltage } V + \text{the voltage drops in the transformer and generator impedance}$. It is illustrated in Figure 6. Current flows in

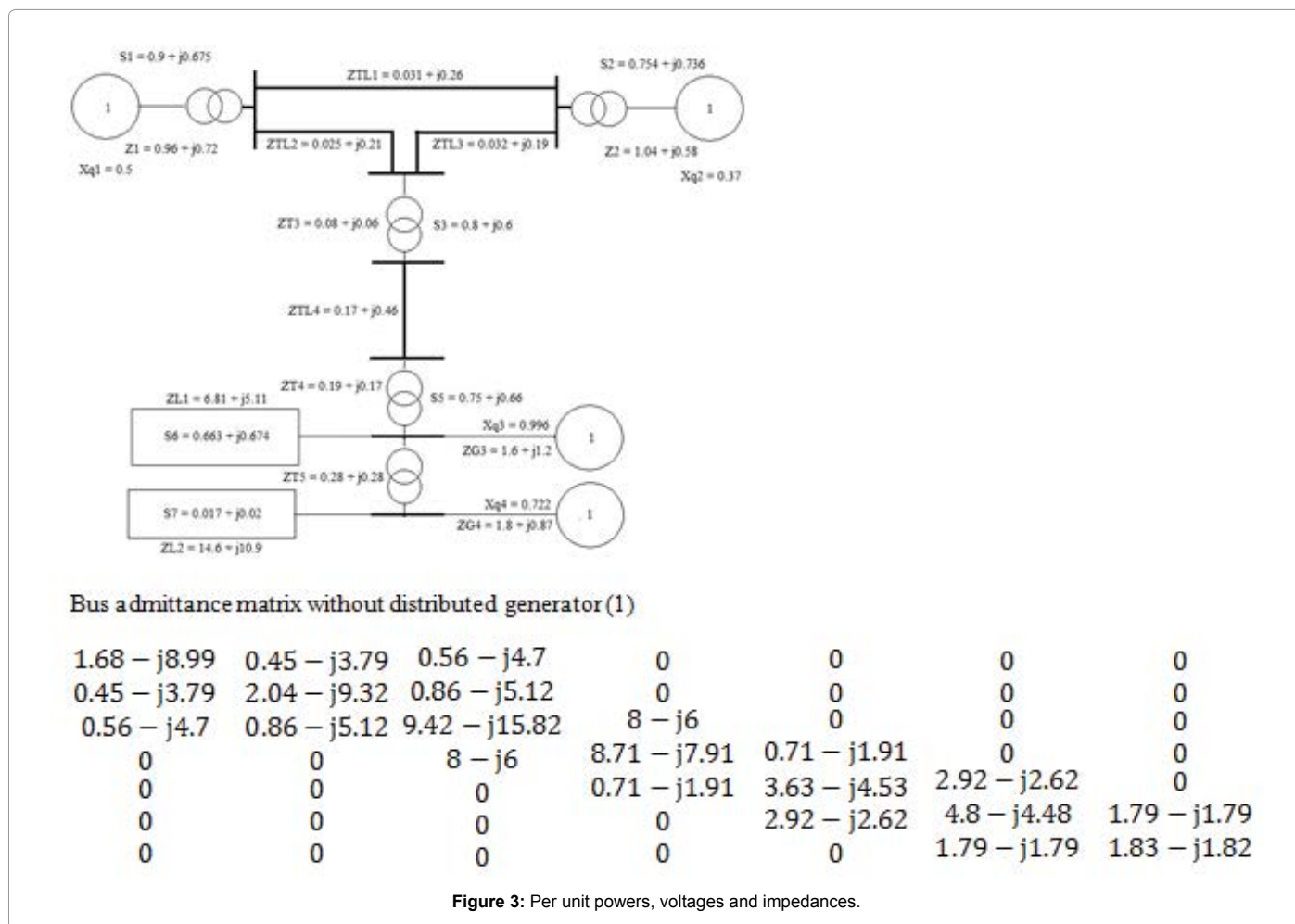

Bus	V. 1	V. 2	V. 3	V. 4	V. 5	V. 6	V. 7
Generator 1	1	1.106	1.037	1.115	1.254	1.329	1.415
Generator 2	1.127	1	1.045	1.123	1.263	1.338	1.426
Transmis. 3	1.195	1.182	1	1.097	1.269	1.360	1.465
Transmis. 4	1.272	1.259	1.091	1	1.229	1.347	1.482
Transmis. 5	1.662	1.653	1.520	1.458	1	1.238	1.504
Distribute 6	1.714	1.706	1.587	1.53	1.137	1	1.381
Distribute 7	1.668	1.660	1.543	1.48	1.096	0.958	1

Table 1: Bus voltages magnitude with different slack bus for the grid without distributed generators.

0.4602+j 0.3429	0.4515+ j0.2667	0.4544 +j0.29	0.4474 +j0.290 8	0.4293+ j0.2549	0.4125+ j0.2428	0.4045+ j0.236
0.4515+ 0.2667	0.4694+ j0.3402	0.4579 +j0.29	0.4508 +j0.293	0.4326+ j0.2569	0.4157+ j0.2447	0.4075+ j0.238
0.4544+ 0.2949	0.4579+ j0.2973	0.4693 +j0.38	0.4620 +j0.381	0.4464+ j0.3389	0.4292+ j0.3233	0.4211+ j0.315
0.4474+ 0.2908	0.4508+ j0.2931	0.4620 +j0.38	0.5335 +j0.434	0.5154+ j0.3864	0.4955+ j0.3685	0.4860+ j0.359
0.4293+ 0.2549	0.4326+ j0.2569	0.4464 +j0.33	0.5154 +j0.386	0.6738+ j0.7653	0.6488+ j0.7312	0.6372+ j0.713
0.4125+ 0.2428	0.4157+ j0.2447	0.4292 +j0.32	0.4955 +j0.368	0.6488+ j0.7312	0.8053+ j0.8606	0.7907+ j0.840
0.4045+ 0.2364	0.4075+ j0.2383	0.4211 +j0.31	0.4860 +j0.359	0.6372+ j0.7138	0.7907+ j0.8401	1.0536+ j1.092

Bus impedance matrix without distributed generator. (2)

1.68 - j8.99	0.45 - j3.79	0.56 - j4.7	0	0	0	0
0.45 - j3.79	2.04 - j9.32	0.86 - j5.12	0	0	0	0
0.56 - j4.7	0.86 - j5.12	9.42 - j15.82	8 - j6	0	0	0
0	0	8 - j6	8.71 - j7.91	0.71 - j1.91	0	0
0	0	0	0.71 - j1.91	3.63 - j4.53	2.92 - j2.62	0
0	0	0	0	2.92 - j2.62	5.2 - j4.78	1.79 - j1.79
0	0	0	0	0	1.79 - j1.79	2.28 - j2.04

Bus admittance matrix with distributed generator. (3)

0.3657+j 0.3075	0.3563 +j0.231	0.3536 +j0.243	0.3311 +j0.232	0.2680 +j0.126	0.2140 +j0.093	0.1806+ j0.0672
0.3563+j 0.2310	0.3735 +j0.304	0.3562 +j0.245	0.3336 +j0.234	0.2701 +j0.127	0.2157 +j0.094	0.1819+ j0.0678
0.3536+j 0.2434	0.3562 +j0.245	0.3634 +j0.316	0.3398 +j0.301	0.2828 +j0.175	0.2268 +j0.131	0.1928+ j0.0980
0.3311+j 0.2323	0.3336 +j0.234	0.3398 +j0.301	0.3925 +j0.343	0.3262 +j0.199	0.2616 +j0.149	0.2223+ j0.1113
0.2680+j 0.1267	0.2701 +j0.127	0.2828 +j0.175	0.3262 +j0.199	0.4411 +j0.414	0.3571 +j0.316	0.3085+ j0.2442
0.2140+j 0.0934	0.2157 +j0.094	0.2268 +j0.131	0.2616 +j0.149	0.3571 +j0.316	0.4405 +j0.369	0.3796+ j0.2845
0.1806+j 0.0672	0.1819 +j0.067	0.1928 +j0.098	0.2223 +j0.111	0.3085 +j0.244	0.3796 +j0.284	0.5710+ j0.4345

Bus impedance matrix with distributed generator. (4)

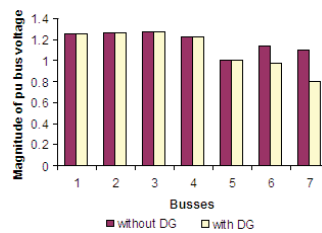

Figure 4: Magnitude of bus voltages at each bus for slack bus 5.

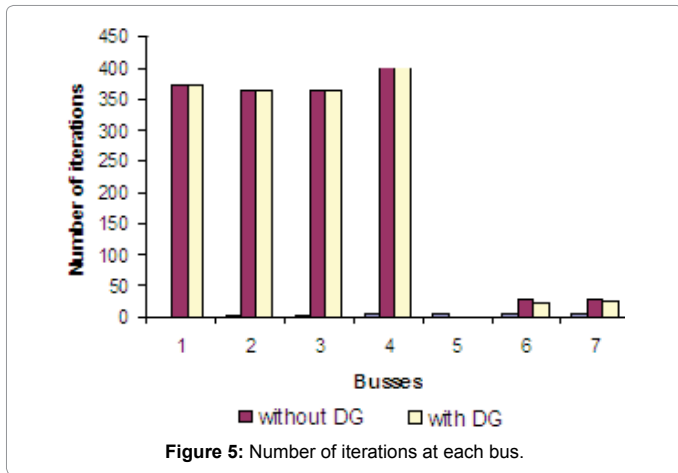

Figure 5: Number of iterations at each bus.

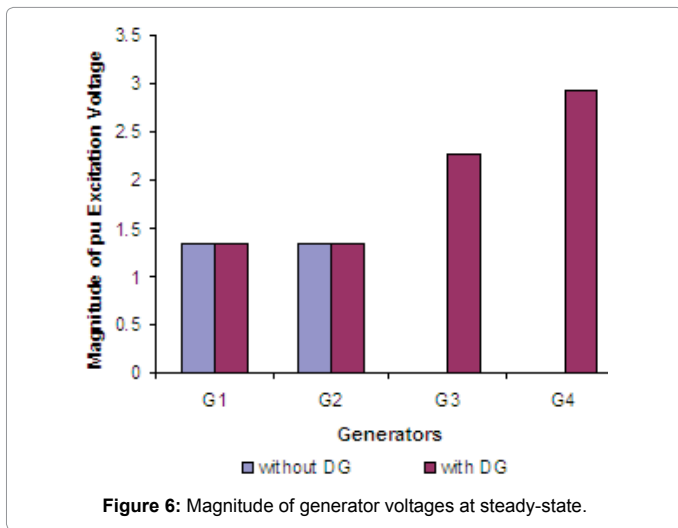

Figure 6: Magnitude of generator voltages at steady-state.

the 4 lines are obtained and the magnitudes of line flow and line loss are shown in Figures 7 and 8 respectively.

It is noted from Figure 8 that the line loss is smaller when selecting bus 5 as slack than selecting another slack bus.

Short Circuit Investigation

A symmetrical 3-phase fault is used, and the calculation of fault current in each bus is obtained. Figure 9 shows the magnitude of fault currents in both cases using the diagonal of the impedance matrix (2) and (4) with the bus voltages of Figure 4. The calculation of the transient bus voltages during fault are given in Tables 2 and 3.

In Figure 9, fault current without distributed generators in power grid network is lower than the fault current with distributed generators. It is clearly indicating that placing distributed generators at bus 6 and 7 causes an increase of the fault current at all buses. This shows that the presence of distribution generators in a network affects the short circuit level of the network. It creates an increase in the fault currents when compared to normal conditions at which no distributed generators is installed in the network. The maximum increase is at bus bar 6 which contributed 75.25% and this seems to be quite reasonable as the distributed generators is located at this bus. The distance between the distributed generators and the fault is too small and the current is not

damped at all. This close distance leads to an increase in the percentage of distributed generators contribution to the fault, consequently increasing the value of fault current. Increase in fault current at other buses is less than that at bus 6 due to the far distance of the fault location from both utility and distributed generators. The second highest fault current reported is with the fault location at bus 5 which has a fault percentage of 68.37%.

Tables 2 and 3 shows the magnitude of bus voltages during fault at each bus for the case of grid with and without solar power injection by using bus 5 as slack. By comparing the magnitude of bus voltage among

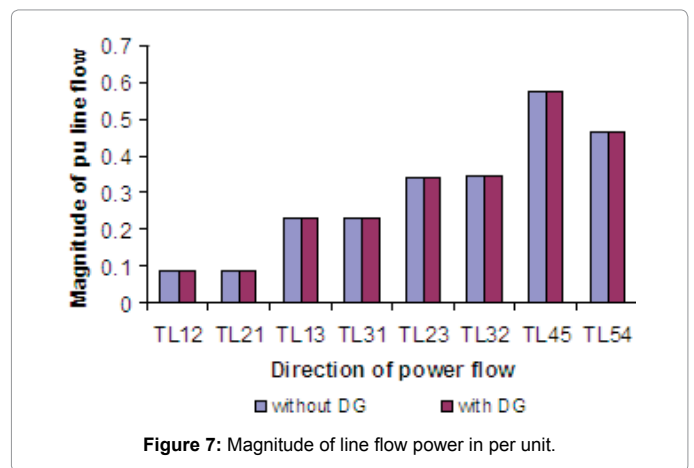

Figure 7: Magnitude of line flow power in per unit.

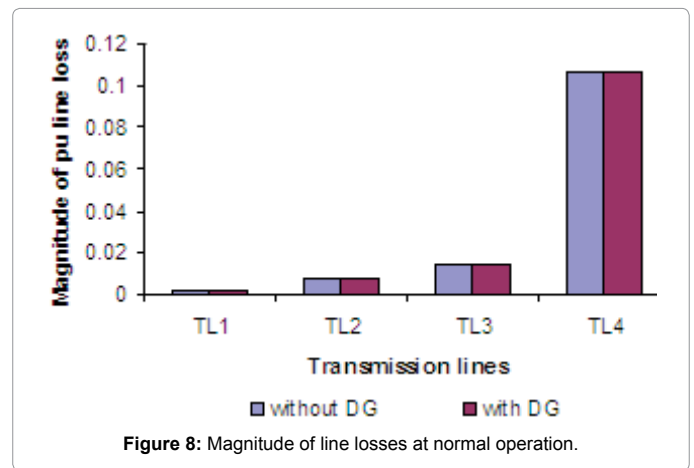

Figure 8: Magnitude of line losses at normal operation.

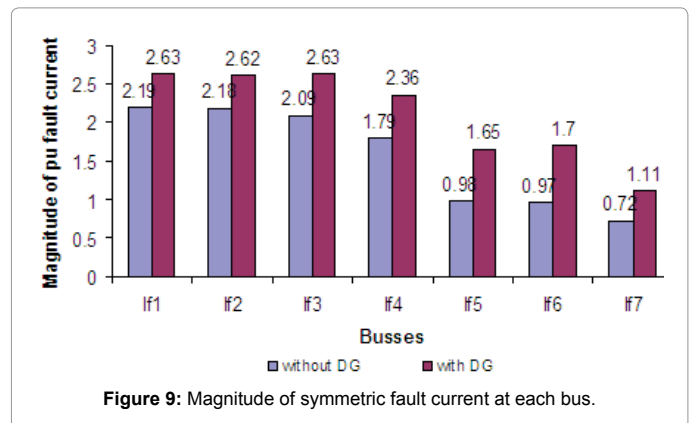

Figure 9: Magnitude of symmetric fault current at each bus.

Bus	1	2	3	4	5	6	7
Fault Current I_f	2.19 $\angle -39.12$	2.18 $\angle -39.0$	2.09 $\angle -40.28$	1.79 $\angle -38.88$	0.98 $\angle -48.6$	0.97 $\angle -47.9$	0.72 $\angle -47.4$
V1	0 $\angle 0$	0.17 $\angle 43.32$	0.16 $\angle 34.47$	0.31 $\angle 8.21$	0.79 $\angle 7.07$	0.82 $\angle 6.03$	0.93 $\angle 2.85$
V2	0.16 $\angle 38.24$	0 $\angle 0$	0.15 $\angle 29.75$	0.31 $\angle 5.31$	0.80 $\angle 5.95$	0.82 $\angle 4.94$	0.94 $\angle 1.89$
V3	0.14 $\angle 49.95$	0.14 $\angle 51.67$	0 $\angle 0$	0.20 $\angle -8.45$	0.74 $\angle 7.14$	0.77 $\angle 7.14$	0.90 $\angle 6.12$
V4	0.15 $\angle 61.99$	0.15 $\angle 63.92$	0.03 $\angle 132.1$	0 $\angle 0$	0.63 $\angle 12.5$	0.66 $\angle 12.51$	0.81 $\angle 10.87$
V5	0.18 $\angle 116.4$	0.18 $\angle 118.0$	0.18 $\angle 159.5$	0.16 $\angle 164.8$	0 $\angle 0$	0.06 $\angle 7.15$	0.31 $\angle -1.86$
V6	0.17 $\angle 52.86$	0.17 $\angle 54.23$	0.05 $\angle 67.65$	0.04 $\angle 31.32$	0.18 $\angle 5.69$	0 $\angle 0$	0.30 $\angle -2.18$
V7	0.16 $\angle 57.2$	0.15 $\angle 58.84$	0.04 $\angle 89.56$	0.03 $\angle 47.12$	0.16 $\angle 7.21$	0.02 $\angle -173$	0 $\angle 0$

Table 2: Fault current and transient bus voltage at each bus for the case of grid without distributed generators.

Bus	1	2	3	4	5	6	7
Fault Current I_f	2.63 $\angle -42.5$	2.62 $\angle -42.3$	2.63 $\angle -41.8$	2.36 $\angle -40.9$	1.65 $\angle -43.2$	1.70 $\angle -42.8$	1.11 $\angle -43.19$
V1	0 $\angle 0$	0.20 $\angle 39.6$	0.16 $\angle 34.47$	0.31 $\angle 8.21$	0.79 $\angle 7.07$	0.88 $\angle 5.04$	1.06 $\angle 1.60$
V2	0.20 $\angle 35.38$	0 $\angle 0$	0.15 $\angle 29.75$	0.31 $\angle 5.31$	0.80 $\angle 5.95$	0.89 $\angle 4.03$	1.06 $\angle 0.76$
V3	0.21 $\angle 42.11$	0.20 $\angle 43.1$	0 $\angle 0$	0.20 $\angle -8.45$	0.74 $\angle 7.14$	0.84 $\angle 7.14$	1.04 $\angle 5.52$
V4	0.23 $\angle 39.28$	0.22 $\angle 40.0$	0.04 $\angle 20.76$	0 $\angle 0$	0.63 $\angle 12.51$	0.74 $\angle 12.51$	0.97 $\angle 9.50$
V5	0.35 $\angle 1.91$	0.34 $\angle 42.4$	0.21 $\angle 48.18$	0.19 $\angle 53.06$	0 $\angle 0$	0.19 $\angle 5.59$	0.57 $\angle 3.72$
V6	0.42 $\angle 20.89$	0.42 $\angle 21.0$	0.31 $\angle 17.23$	0.29 $\angle 17.78$	0.19 $\angle -7.48$	0 $\angle 0$	0.45 $\angle 1.25$
V7	0.34 $\angle 18.4$	0.34 $\angle 18.6$	0.25 $\angle 14.94$	0.23 $\angle 15.57$	0.15 $\angle -10.5$	0.008 $\angle 167.4$	0 $\angle 0$

Table 3: Fault current and transient bus voltage at each bus for the case of grid with distributed generators.

all the bus, bus voltages nearby the bus bar which fault occurs will be increased whereas bus bar which is far apart to the fault also increases when injection the distributed generators. As the distance between the bus bar and the fault location increases the value of the bus voltage increases.

The generator excitation voltage values during transient state are changed according to the location of the fault. Thus, for a fault at each bus, excitation voltages of the 4 generators have different values. Figure 10 shows the generator voltage values in per unit when the fault occurs at bus 1 in the 2 cases.

Current flow, line flow and line losses are also calculated in each

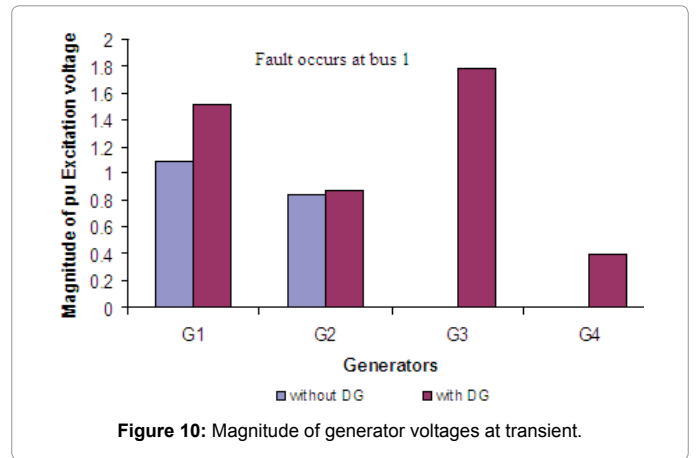

Figure 10: Magnitude of generator voltages at transient.

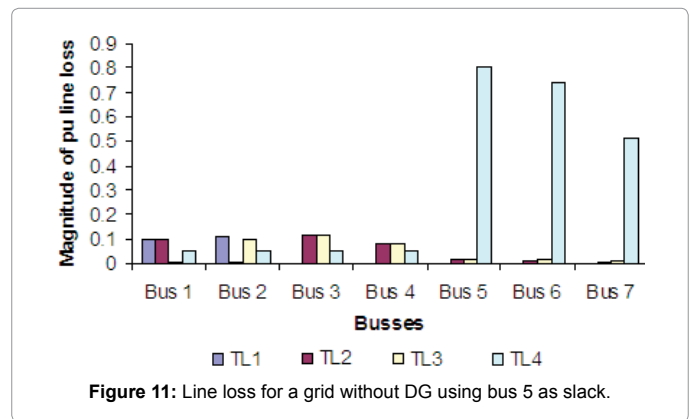

Figure 11: Line loss for a grid without DG using bus 5 as slack.

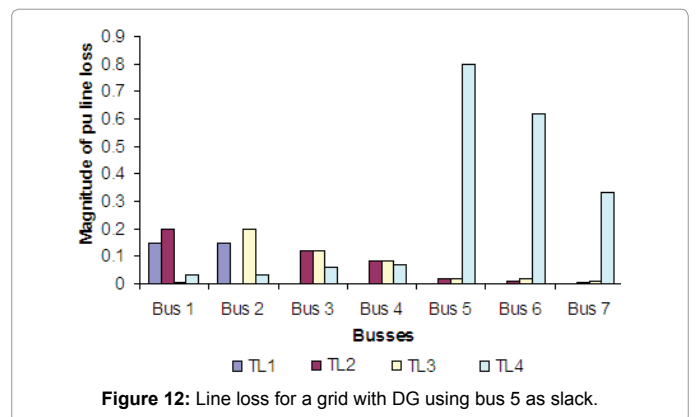

Figure 12: Line loss for a grid with DG using bus 5 as slack.

transmission line when the fault occurs at each bus. Figures 11 and 12 illustrate the line loss in the 4 lines at each bus fault occurrence.

The figures show the magnitude of line loss in each transmission lines during fault at each bus for the case of grid with and without distributed generators by using bus 5 as slack. By comparing the power loss at bus 5, 6 and 7, the magnitude of power loss is observed to decrease when there is additional generators which is important to achieve a better reliability of the system with reduced losses. Normally, it is assumed that losses decrease when generation takes place closer to the load site. According to [8], researchers concluded that solar power injection reduces the transmission losses but Figure 12 shows that locating distributed generators will be minimizing power losses at bus [5-7] and maximizing power losses at bus [1-4]. By comparing the power loss at bus 3, 4 there are slightly increase on power loss for each transmission line. This indicates that there is effect on power loss when at bus 3, 4 in case of with DG. Power loss will be significant decrease when the transmission line is closer to the location of DG and slightly increase when the location of distributed generators is far away. When fault occurs at bus 5, power loss is highest for the 2 cases. This indicates that protection devices need to be considered to reduce power loss. When a short to earth or power loss is greater than 0.1 per unit MVA occurs, protection is needed to disconnect all the equipment to save all lines. Impedance relay can be used for protection the transmission line. When a fault appears on the transmission line, the impedance setting in the relay is compared to the apparent impedance of the transmission line from the relay terminals to the fault. If the relay setting is determined to be below the apparent impedance it is determined that the fault is within the zone of protection.

Results

Stability can be determined by the power-angle formula (5) at both steady-state and transient. The power angle has 3 values, 2 at pre-fault (the initial δ_o and maximum δ_m) and one at transient (the critical δ_{cr}). Critical angle is calculated at each bus when the fault occurs at any of the 7 buses and as referred to one of the 4 generators. Values given in Tables 2 and 3, impedances (2), (4) and Figures 4, 7 and 10 are involved in the analysis.

$$P_i = \frac{E_i V_j}{X_{Tj}} \sin \delta + \frac{V_j^2 (X_{Tj} - X_{qi})}{2 X_{Tj} X_{qi}} \sin 2\delta \quad \text{pre - fault}$$

$$P'_i = \frac{E'_i V'_j}{X'_{Tj}} \sin \delta + \frac{V'_j{}^2 (X'_{Tj} - X'_{qi})}{2 X'_{Tj} X'_{qi}} \sin 2\delta \quad \text{transient}$$

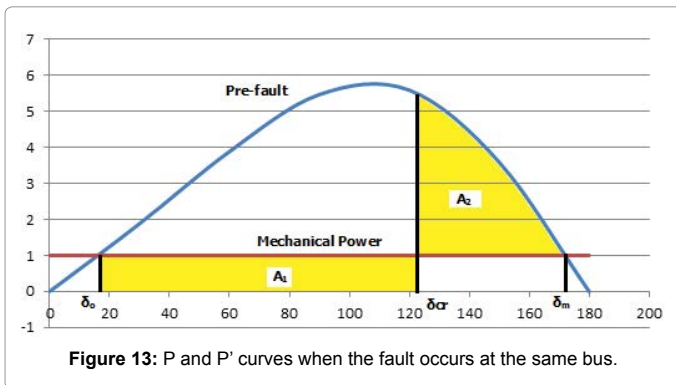

Figure 13: P and P' curves when the fault occurs at the same bus.

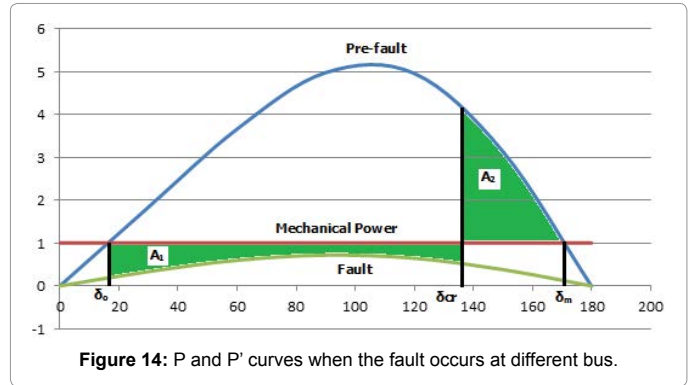

Figure 14: P and P' curves when the fault occurs at different bus.

Bus	1	2	3	4	5	6	7
1	122.7	138.4	138.2	170			
2	137.7	123.3	137.3	163.6			
3	128.7	128.7	117.4	128.2			
4	120.5	120.5	111.5	109.8			
5	68.2	68.2	68.2	67.5	63	81.1	70.4
6	81.5	64.6	61.2	68	65.1	60.9	63.7
7	52.6	52.9	50.9	50.7	52.2	49.1	50.4

Table 4: Critical angle at each bus as referred to G1, without DG.

Bus	1	2	3	4	5	6	7
1	116.8	129.3	128.4	145			
2	129	117.6	128	144.8			
3	118.4	118.4	110.2	123.3			
4	110.6	110.6	102	101.4	128.2		
5	63.1	63.1	63.1	62.5	60	60.7	69.3
6	62	62	60	60.1	62.2	60.13.8	64.7
7	56.2	55	54.1	54	55.4	51.4	51.5

Table 5: Critical angle at each bus as referred to G2, without DG.

Bus	1	2	3	4	5	6	7
1	127.2		163.3				
2	165.8	127.9	156.6				
3	166.3	161.8	126.4	161.8			
4	164.7	159.4	126.2	121.8			164.7
5			136	131	104	130.9	
6					147.7	109.2	
7			151.8	137	113.9	91.6	74.9

Table 6: Critical angle at each bus as referred to G1 and with DG.

Bus	1	2	3	4	5	6	7
1	122.6	139.2	135	154.6			
2	139.6	123.2	134.7	154.3			
3	138.2	137.3	121.5	136			
4	133.7	132.7	118.5	116			
5	110.7	110	99.5	125	97.1	125	152.5
6			138.5	134.7	120.1	103.5	
7	119	119	105.6	103.1	95.5	85.5	85.5

Table 7: Critical angle at each bus as referred to G2 and with DG.

Where the subscripts, $i = 1, 2, 3, 4, j = 1, 2, \dots, 7$

P_i is the mechanical turbine power at steady-state = 1 per unit.

Equal area criterion is applied to obtain the critical stability which relates to the critical clearing angle. Figures 13 and 14 are example of

Bus	1	2	3	4	5	6	7
1	134		164.5				
2		140.2	161.8				
3		145	143.7	155			
4			140.5	136.5			
5			156	151	124.7	151.1	
6					166.2	127.6	
7				166.9	138.1	115.4	114.8

Table 8: Critical angle at each bus as referred to G3 and with DG.

Bus	1	2	3	4	5	6	7
1	142.6	146.9	146	147.9	168.2	173.3	
2	148.6	143	147.4	151.2	150.2		
3	146.6	146.4	142.3	146.4	162.5	168.8	
4	141.1	143.9	140.4	139.1	153.9	157.5	171.8
5	135.9	135.8	133.2	132.8	129.1	132.8	140.9
6	142.4	142.4	141.2	138.8	136.3	131.8	141.1
7	128.5	128.5	126.4	125.9	124.1	120.5	120.7

Table 9: Critical angle at each bus as referred to G4 and with DG.

Bus	1	2	3	4	5	6	7
I_{pu}	2.18	2.19	2.09	1.79	0.98	0.97	0.72
I_A	2289	2299	2194	3915	2143	2828	1575
t_{cr}	0.852	0.856	0.825	0.784	0.516	0.527	0.436

Table 10: Per unit fault current and critical time at each bus.

the equal area. Figure 13 shows the areas in a certain bus when the fault occurs at the same bus, where $P' = 0$ since its bus voltage drops to 0, while Figure 14 shows the areas as related to another bus, where $P' \neq 0$, since its bus voltage drops to a certain value.

Critical angle is obtained in degree by trial and error or MATLAB code taking several iterations for an accurate result. Tables 5-10 present the values obtained for the critical clearing angles in each bus due to fault occurs at each bus for the cases of without and with distributed generators as referred to each of the 4 generators. The empty slots indicate that the angle is indeterminate in which the power-angle curve at transient is closed to the steady-state curve, where the areas are undefined and thus the system shows that the stability is performed, since the generator is not swinging. At these cases, there is no critical angle since it may exceed the 180 degrees and the initial angle at transient is approximately equals the initial angle at steady-state. Figure 15 illustrate this case.

It can be recognized from results in Tables 5 and 6 that when the distributed load bus 6, 7 have no generators connected the chance of instability occur in the power stations generators 1 and 2 is high since the critical angle in bus [5-7] are low for any fault can occur at any bus. But when connecting the distributed generators to bus 6 and 7, the critical angles increase at these buses from the results of Tables 7 and 8, which means that the stability is improved for generators 1 and 2, although the fault currents are high in these buses as compared to without distributed generators case. For the results of Tables 9 and 10 it is believed that the distributed generators 3, 4 are seems to be stables for any fault can occur at any bus since the values of critical angle is moderate.

This stability results with distributed generators are not found in the literatures and therefore it is considered a new discovery.

Critical clearing time can therefore be found from the form (6)

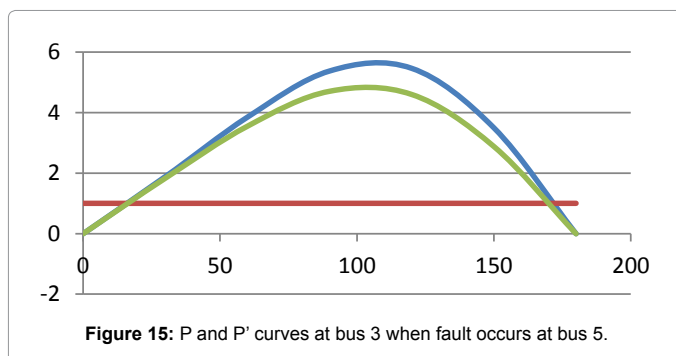

Figure 15: P and P' curves at bus 3 when fault occurs at bus 5.

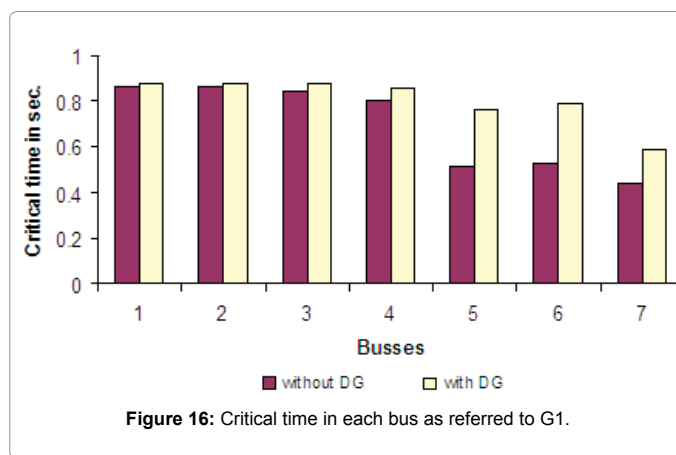

Figure 16: Critical time in each bus as referred to G1.

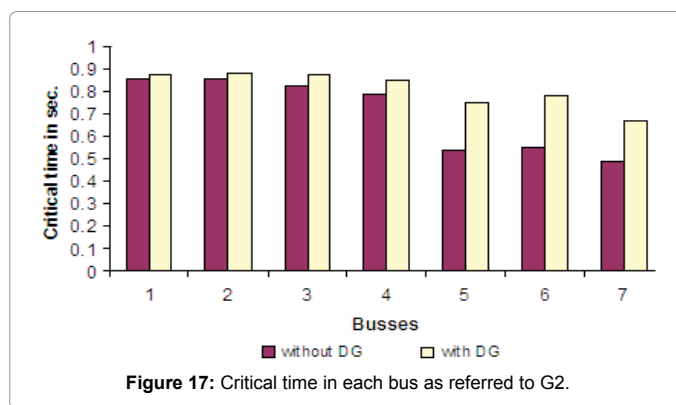

Figure 17: Critical time in each bus as referred to G2.

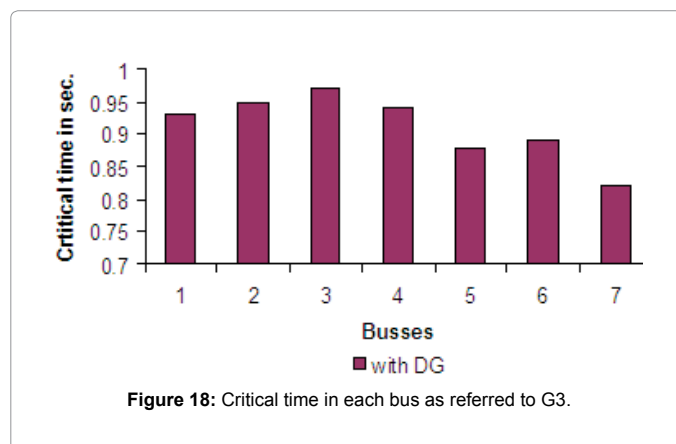

Figure 18: Critical time in each bus as referred to G3.

which gives the maximum clearing time before instability and is used as the operating time in the over current relay to obtain the multiple time setting. Figures 16-19 show the critical time values in second in each bus as referred to the generators.

$$t_{cr} = \sqrt{\frac{2J(\delta_{cr} - \delta_o)\pi}{180 P_i}}$$

where J is the moment of inertia which is assumed to be 2 per unit and δ_o is the initial angle calculated from the pre-fault form of (5).

It is seen that when the distributed generators are injected in the load busses the critical time increased in all busses which indicates that it gives more time to clear before instability. This states that grid with distributed generators is more stable than the grid without distributed generators, although the fault currents are much higher.

Protection

This section determines the selection of current transformers for over current relays types CO8, CO9 and CO11, which relates to standard inverse SI, very inverse VI and extremely inverse EI, respectively. This is followed by calculating time multiple setting TMS and current settings of the relay at each bus considering the optimum fault currents and operating times are the minimum values given in Figures 9, 15 and 16. Table 11 summarizes the per unit currents, actual current in Amper and operating times in sec.

The base currents are calculated from the base voltage at each bus and 500 MVA base powers using the formula (7)

$$S = \sqrt{3} V_i I^*, i = 1, 2, \dots, 7 \tag{7}$$

The distributed bus 6, 7 are protected from the feeders, 3 feeders connected to bus 6 and 20 to bus 7.

Current transformers therefore, can be selected based on the values of actual fault current given in table 11. Pick up current I_p and current settings as well as the time multiple setting for each relay type are then determined from (8) and given in Tables 12 and 13.

$$ST \text{ (CO8)} \quad t_o = TMS \frac{0.14}{\left(\frac{I_f}{I_p}\right)^{0.02} - 1} \tag{8}$$

$$VI \text{ (CO9)} \quad t_o = TMS \frac{13.5}{\left(\frac{I_f}{I_p}\right) - 1}$$

$$EI \text{ (CO11)} \quad t_o = TMS \frac{80}{\left(\frac{I_f}{I_p}\right)^2 - 1}$$

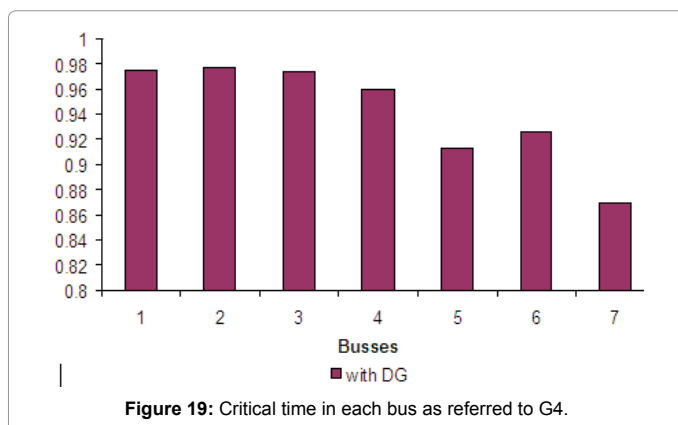

Figure 19: Critical time in each bus as referred to G4.

Bus	1	2	3	4	5	6	7
CT	2000/5	2000/5	2000/5	4000/5	2000/5	2500/5	1500/5
I_f/I_p	5.7225	5.7475	5.485	4.8937	5.3575	5.656	5.25
SI	3.9432	3.9338	4.0431	4.3385	4.1008	3.9703	4.1517
VI	2.8586	2.8436	3.0100	3.4671	3.0981	2.8995	3.1764
EI	2.5199	2.4974	2.7505	3.4861	2.8878	2.5814	3.0117

Table 11: Current transformer settings in each bus and relay type.

Bus	1	2	3	4	5	6	7
SI	0.216	0.217	0.204	0.181	0.126	0.133	0.105
VI	0.298	0.301	0.274	0.226	0.167	0.182	0.137
EI	0.338	0.343	0.3	0.225	0.179	0.204	0.145

Table 12: TMS sec. in each relay.

By this setting relays will trip before critical time when a symmetric fault occurs at its bus.

Conclusion

A detailed analysis and computation are presented in this paper for load flow, short circuit, stability and protection by taking a simple example of a limited 7-bus power grid system in 2 cases, without and with distributed generators. Calculations of bus voltages at steady-state and transient with fault current at each bus are investigated and compared by Gauss method and impedance matrix in per unit values. Stability analysis based on power-angle characteristics and equal area criterion to calculate the critical load angle and critical clearing time for the 2 cases is given for each bus when a symmetric 3-phase fault occurs at each bus. These is followed by selecting suitable current transformers and setting the current and time multiple setting of three types of over current relays that are set to trip at critical stability time to protect the system.

Optimum values of bus voltages are determined to select a suitable slack bus that gives lower power loss in the grid. The results show that injecting distributed generators don't have any negative impact on the grid, but help to reserve the energy consumption in the load bus. Moreover, distributed generators make the grid system more stable. This is because of the increasing value of critical clearing angle in the result of with distributed generators in most of busses for any fault location.

However, penetration of any distributed generators into a power grid system causes an increase in the fault level of the network at any fault location. Presence of the distributed generators in a location close to the substation or bus bar causes a decrease in the bus voltage during fault and the bus voltage will be increase for bus bar that is far away from the fault location but the fault current is still increased. As the distance between the bus bar and the fault location increases the value of the bus voltage increases. In the 3-phase fault, the voltages at faulted bus phases dropped to zero during the fault.

Appendix

$$\text{Gauss-Seidel bus voltage } V_i^{k+1} = \frac{P_i - jQ_i - \sum_{j=0, j \neq i}^n Y_{ij} V_j^k}{Y_{ii}}$$

Equal area criteria

$$A_1 = P_m (\delta_o - \delta_{cr}) - \int_{\delta_o}^{\delta_{\alpha}} P' d\delta = A_2 = \int_{\delta_{cr}}^{\delta_n} P d\delta - P_m (\delta_m - \delta_{cr})$$

Bus current $I_i = Y_{nn} V_i^n$

Fault current $I_{fi} = \frac{V_i^n}{Z_{ii}}$

Line flow $S_{ij} = V_i I_{ij}^*$ $S_{ji} = V_j I_{ji}^*$

Line Loss $S_{Lij} = S_{ij} + S_{ji}$

Transient bus voltage $V_i = 1 - Z_{ij} I_{fi}$

References

1. Kundur P, Paserba J, Ajarapu V, Anderson G, Bose A, et al. (2004) Definition and classification of power system stability. IEEE Transactions on Power Systems 19: 1387-1401.
2. Lee BH, Lee KY (1991) AC study on voltage collapse mechanism in the electric power system. Transactions on Power Systems 6.
3. Tran-Quoc T, Vu-Due T, Feuillet R, Hadsaid N, Sabonnadire JC, et al., (1998) Dynamic analysis on the voltage instability in the vietnam system. IEEE Catalogue 98EX137.
4. Cutsem TV (2000) Voltage instability: phenomena, countermeasures, and analysis methods. Proceeding of the IEEE 88: 208-227.
5. Nor KM (2013) Renewable distributed generation models in three-phase load flow analysis for smart grid. Indonesian Journal of Electrical Engineering and Computer Science 11: 661-668.
6. Singh M, Mahapatra S (2016) Analysis of symmetrical fault in IEEE 14-bus system for enhancing over current protection scheme. International journal of future generation and networking, 9: 51-62.
7. Nallagalva NS, Kirar NK, Agnihotri G (2012) Transient stability analysis of the IEEE 9-bus electric power system. International Journal of Scientific Engineering and Technology 1: 161-166.
8. Barsoum N, Lee CZ (2013) Simulation of power flow and protection of a limited bus grid system with injection solar power. Journal of power and energy engineering 5: 59-69.

Citation: Barsoum N, Asok C, Kwong D, Kit CT (2017) Power Analysis for a Limited Bus Grid System with Distribution Generators. Global J Technol Optim 8: 213. doi: 10.4172/2229-8711.1000213

OMICS International: Open Access Publication Benefits & Features

Unique features:

- Increased global visibility of articles through worldwide distribution and indexing
- Showcasing recent research output in a timely and updated manner
- Special issues on the current trends of scientific research

Special features:

- 700+ Open Access Journals
- 50,000+ editorial team
- Rapid review process
- Quality and quick editorial, review and publication processing
- Indexing at major indexing services
- Sharing Option: Social Networking Enabled
- Authors, Reviewers and Editors rewarded with online Scientific Credits
- Better discount for your subsequent articles

Submit your manuscript at: <http://www.omicsonline.org/submission/>